

Introduction to Optical Networking



Based on:

Rajiv Ramaswami, Kumar N. Sivarajan, "*Optical Networks – A Practical Perspective 2nd Edition*," 2001 October, Morgan Kaufman Publishers



The Information Age

- Dramatic changes in the telecomm industry.
 - Continuing need for more bandwidth
 - Tremendous growth of Internet
 - Exponentially growing WWW information (average phone call: 3 minutes, average internet session: 20 minutes)
- Internet traffic is doubling every 4 to 6 months!!



Growing Bandwidth Need at Home

- DSL lines are widely available for customers with speeds of 1Mbps and higher compared to dial-up lines (2.4-56kbps).
 - A 10% increase of penetration in US households (100million) brings in another 1Tbps of traffic assuming that 10% of these people are on simultaneously.



Growing Bandwidth Need in the Corporate Sector

- Businesses rely on high speed connections.
- Connections are used to interconnect multiple locations as well as connect businesses to the outside world.
- Businesses that used to lease 1.5Mbps lines are common to lease 155Mbps lines nowadays.



Increased Bandwidth Demand vs. Cost of Bandwidth

- Strong correlation.
- Technological advances -> reduced cost of bandwidth.
- Reduced bandwidth cost -> development of new set of applications using more bandwidth.
- Increased bandwidth need drives technological advances.



Deregulation

- Breaking up old phone monopolies.
- Monopolies impede rapid progress (no incentive to reduce costs and provide new services).
- Competition in the market place.
- Start-up service providers with new business plans and companies to provide equipment for them.



Change of Traffic

- New demand is dominated by data traffic opposed to voice communication.
- But most networks are still optimized for carrying voice traffic (legacy).
- Providers have to change their business model and the way they build their networks.



US Deregulation

- -1984: Only one phone company (AT&T) with local Bell operating companies that it owned.
- In 1984 long distance market was deregulated and AT&T was broken up (AT&T only long distance; Baby Bells – local services)
- Other long distance providers (MCI, Sprint, etc.).
- Remaining Bells: SWBC, Bell Atlantic, BellSouth and US West (Qwest)



Fibre Carrier Classification Today

- Size of coverage:
 - Metro Carriers
 - Long-Haul Carriers
- Acces to networks:
 - Public Networks
 - Private Networks

A Public Network

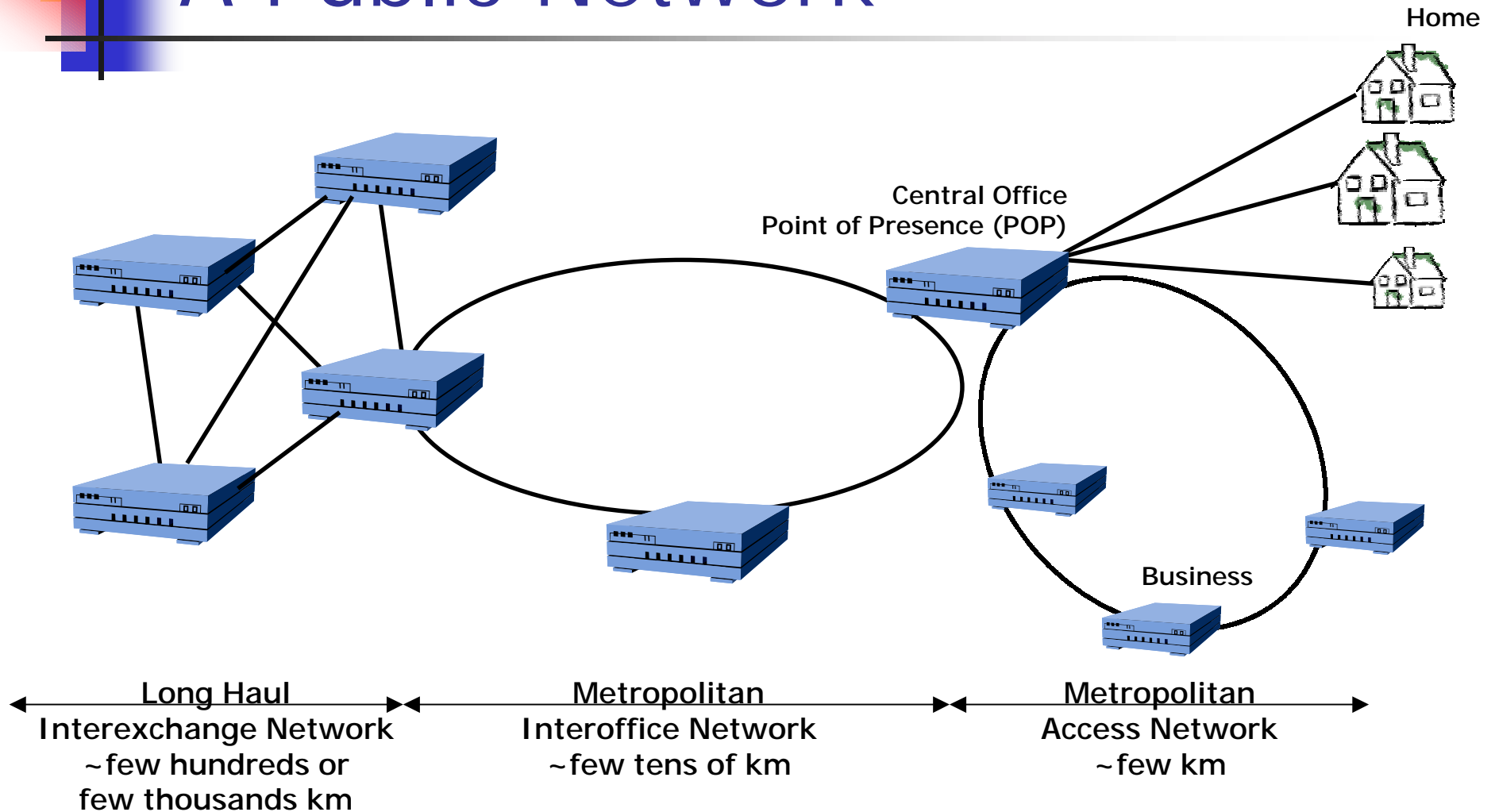



Public Networks

- Links are fibre pairs
- It is imperative to provide multiple paths in long-haul networks.
- Equipment and fibre can belong to several different companies.
- Undersea networks are important long-haul networks.



Services

- Connection oriented services
 - Connection-less services
- OR
- Circuit switched (e.g., PSTN)
 - Leased or private lines (will we see users “dialing” for high speed private lines?)
 - Not efficient for handling bursty data (average and peak rate)



Services

- Packet switched (e.g., Internet - IP)
 - Intended for bursty data transmission
 - Several packet “streams” are multiplexed together.
 - Packet header is added.
 - Packets are switched (or routed) individually.
 - Statistical multiplexing (bandwidth requirement is reduced)



Packet Switched – Statistical Multiplexing

- If load is more than the available bandwidth, queuing/buffering is needed.
- Queuing introduces additional delay and delay jitter.
- Buffer may overflow (packets are dropped)
- Connectionless service – datagram packet service.



Packet Switched – Best Effort

- Network tries its best to relay data from source to destination but offers no guarantees (as opposed to QoS).
- This is today's Internet but it is slowly evolving.
- This is fine for web browsing and file transfers, but...



Packet Switched – Best Effort

- Ethernet is a true best effort architecture.
- FDDI and Frame Relay already included some QoS support.
- ATM had explicit QoS support but came too late, IP was too strong.
- IP is changing (MPLS provides virtual circuits for better utilization of SMPX, differentiated services, integrated services, IPv6)



The Changing Services Landscape

- Line speeds increase from 155Mbps to 2.5Gbps or 10Gbps.
- A carrier's customer may be another carrier.
- Due to increased competition services have to be delivered rapidly (in minutes or less) for even short contract periods (special events, periodical back-ups).



The Changing Services Landscape

Availability

- Availability – the percentage of time the service is available to the user.
- Typically above 99.999% availability is required today (a downtime of less than 5 minutes a year)
- Very fast restoration service (fibre cuts) ~50ms today
- Full redundancy (half the network is reserved)



The Changing Services Landscape

Converging voice and data

- Today voice and data are carried over separate overlay networks.
- Carriers need to maintain multiple networks.
- Carriers would like to migrate to maintaining a single network that enables the delivery of multiple types of services.



Optical Networks

- Optical networks seem to be the medicine for all problems in long-haul and metro networking.
- Optical fibre offers way far more BW than copper cables and is less susceptible to electromagnetic interference (also copper is becoming a scarce resource compared to silicon).
- Recently optical fibres became the top choice for short-distance interconnections in large systems.



Optical Networks

- Optical fibres are widely deployed today (except perhaps in residential access networks, wiring cost, questionable return (although the for the recent 3G auction high bid in GB all homes could have been equipped with fibre))



Optical Networks

- Each *route* in a network comprises many *cables*. Each cable contains many *fibres*.
- A 10 mile long route using 3 cables is said to have 10 route miles and 30 sheath (cable) miles. If each cable has 20 fibres, then the same route is said to have 600 fibre miles.
- By the end of 1998 more than 355,00 sheath miles of fibre (more than 16million fibre miles) in the U.S.

(Optical) Transmission Evolving

- Higher and higher transmission speeds over longer and longer distances.

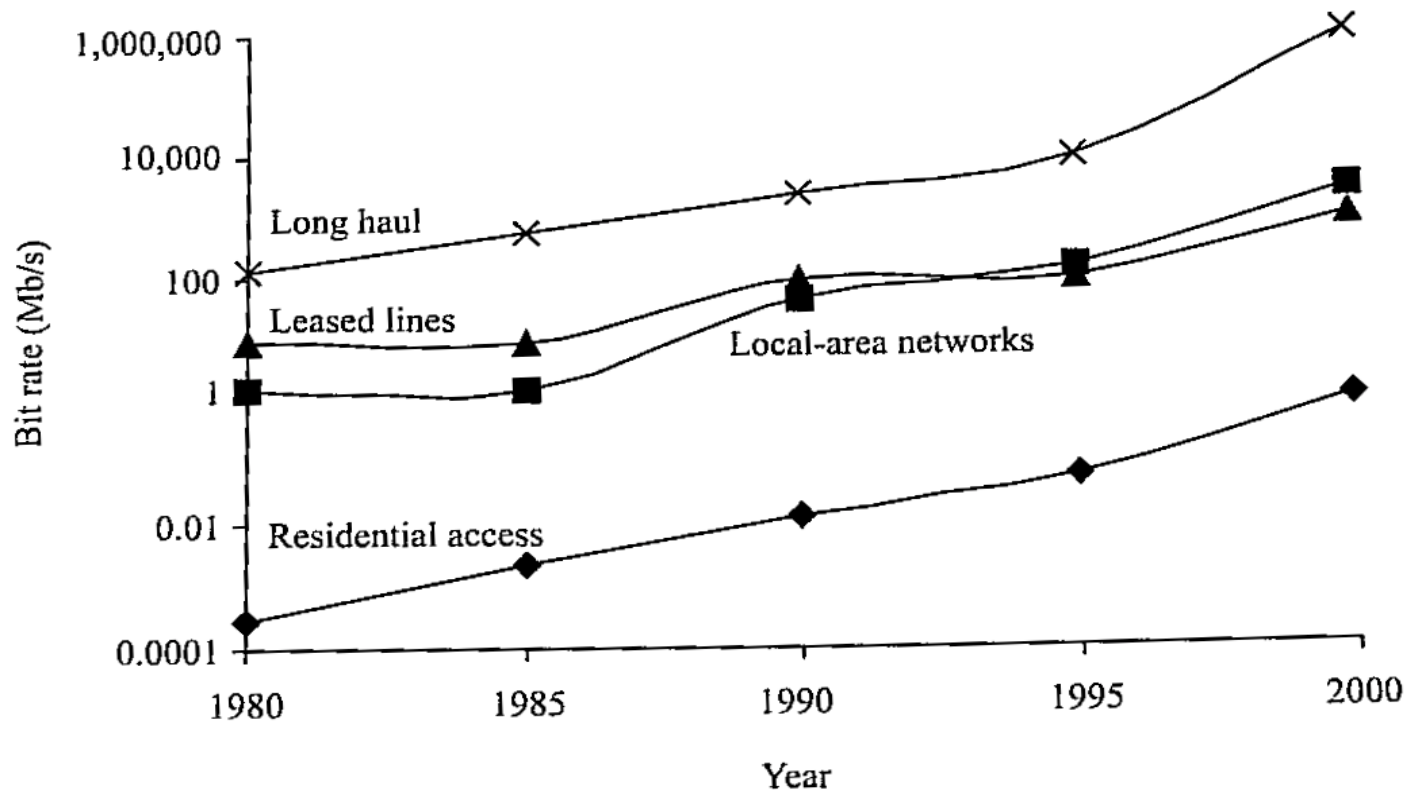



First Glimpse at the Generations of Optical Networks

- First generation optical networks:
 - Optical fibre was used to provide capacity only (lower BER than copper).
 - Switching handled electronically
 - (SONET, SDH, etc.)
- Second generation optical networks:
 - Some routing, switching intelligence is moving into the :
 - Optical Layer



Multiplexing



Multiplexing Techniques

- It is more economical to transmit at higher rates on less fibres than vice versa.
- Two fundamental ways to increase capacity of fibre:
 - Increase the bit rate and multiplex low bit rate streams via TDM
 - Wavelength division multiplexing (WDM), essentially FDM



Time Division Multiplexing

- 64 155Mbps streams may be multiplexed into a 10Gbps stream.
- Today 10Gbps is reality 40Gbps is soon to be reality (compared to Tbps of WDM).
- Optical Time Division Multiplexing is a hot area (multiplexing is done optically). In research labs they can reach 250Gbps but it is still years away. Even so it is not sufficient to use only TDM in fibres.



Wavelength Division Muxing

- Essentially Frequency division multiplexing but a physicist approach.
- Different light-wave light sources (lasers) are used in the same fibre, thus essentially WDM providing with "*virtual fibres*".
- Widely deployed in long-haul (including undersea) networks.
- Recent announcements mention more than 40Tbps using WDM (and TDM).

WDM vs TDM

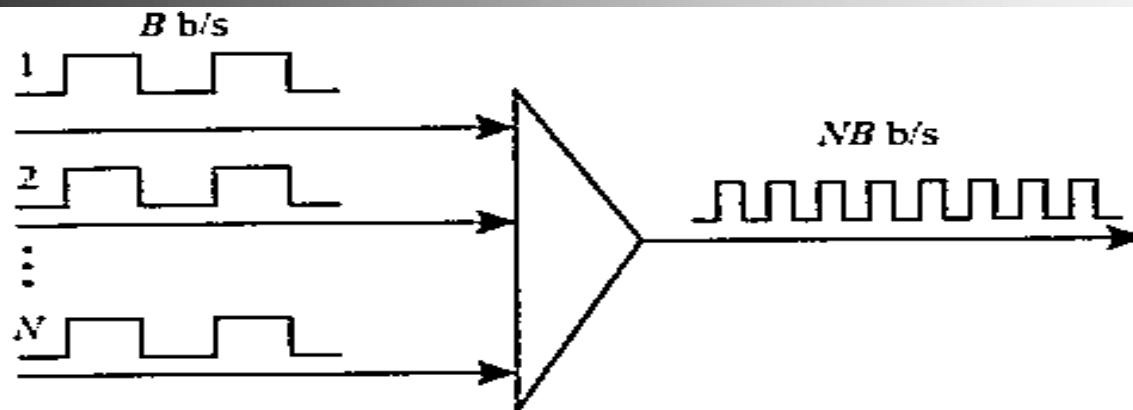

TDM or OTDM mux

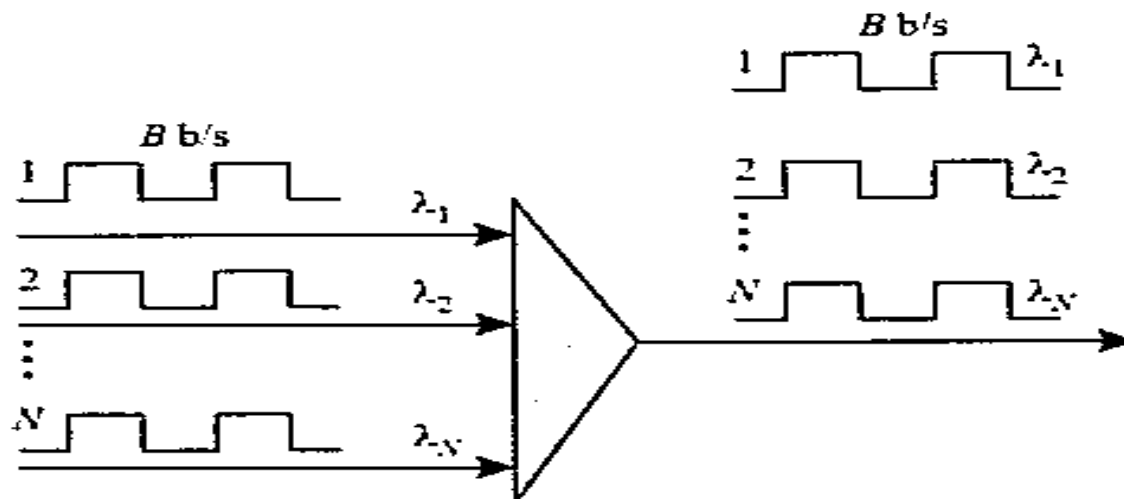

WDM mux



WDM and TDM

- Complementary techniques, thus can be combined.
- The question is what combination to use?
- E.g., on an intended 80Gbps link should we use 32 channels of 2.5Gbps or 8 channels of 10Gbps?
- Commercial systems of 1Tbps are becoming available.

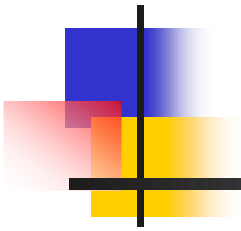

Second Generation Optical Networks



Problems with First Generation Optical Networks

- Optical networks are capable of more than just point-to-point communication.
- Some switching and routing functions can be added.
- Higher data rates => more problems with electronics (switching speeds) (53 bits, 10Gbps => 42.4ns).
- In first generation networks, all data (even data that has to be relayed) is passed through nodes and electronics.



Second Generation Optical Networks

- Data that is passed through the node does not have to be processed by the node: *Wavelength routing network*.
- *Lightpaths*: optical connections carried end-to-end from a source to a destination over a wavelength. At intermediate nodes lightpaths (wavelengths) are routed and may be converted to another wavelength (preferably optically).

A WDM Wavelength Routing Network

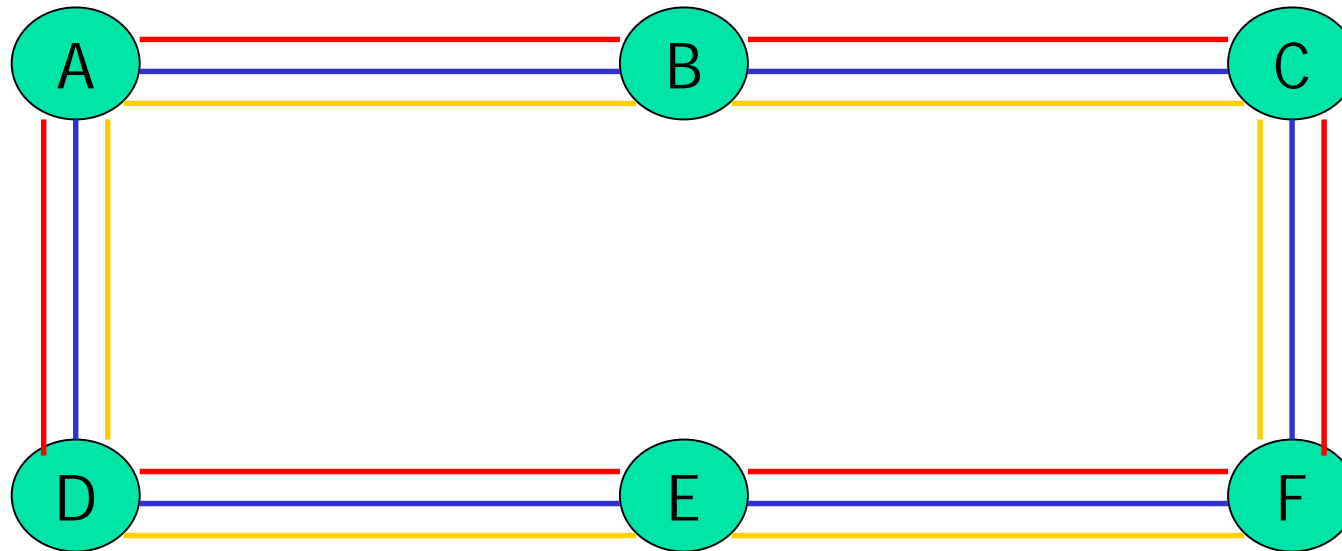

A WDM Wavelength Routing Network

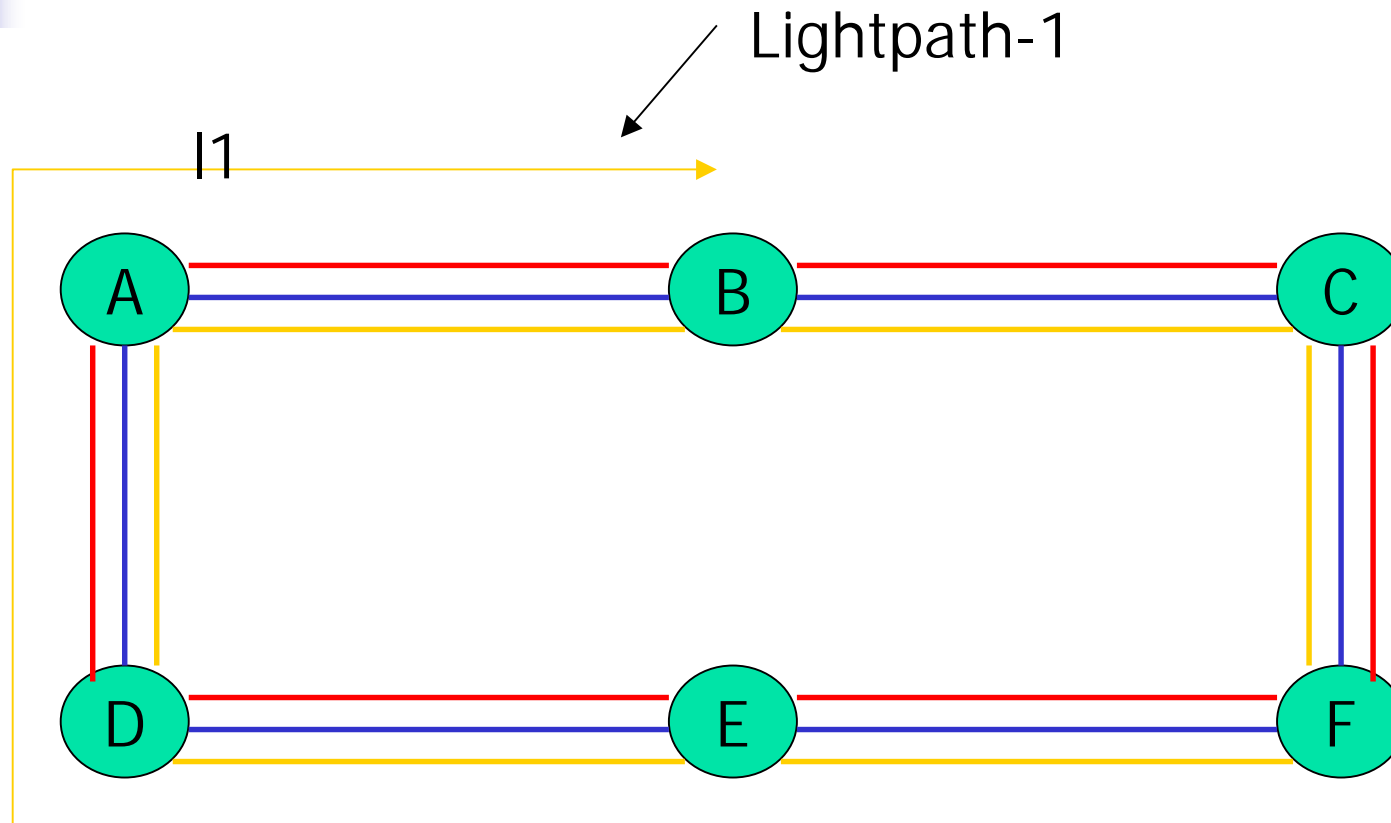

A WDM Wavelength Routing Network

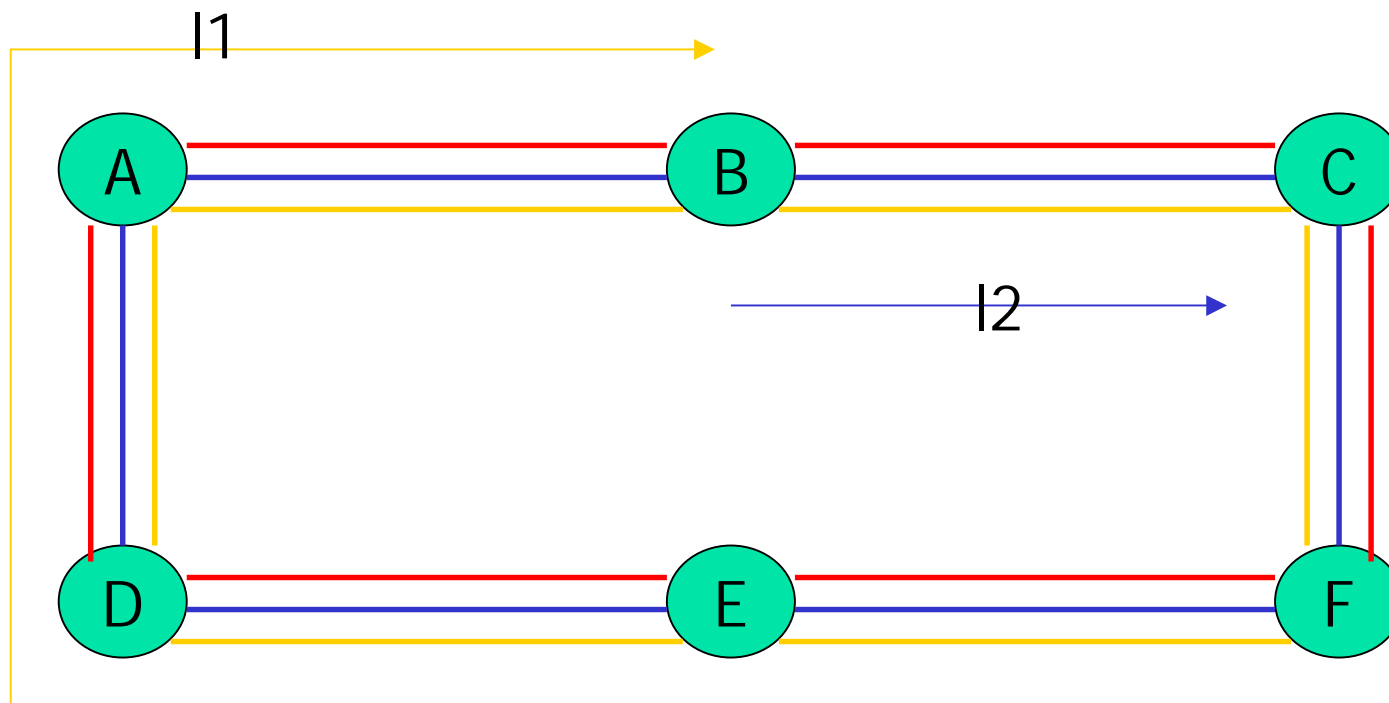

A WDM Wavelength Routing Network

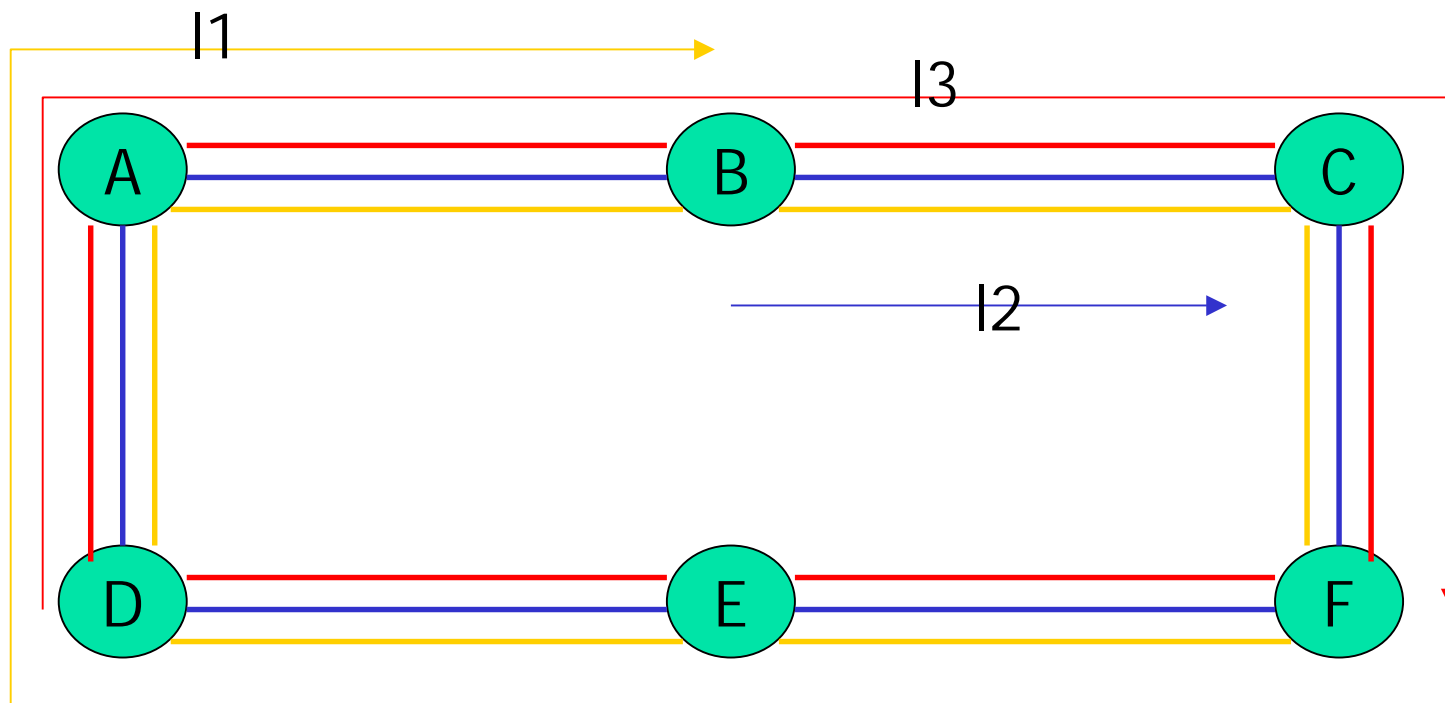

A WDM Wavelength Routing Network

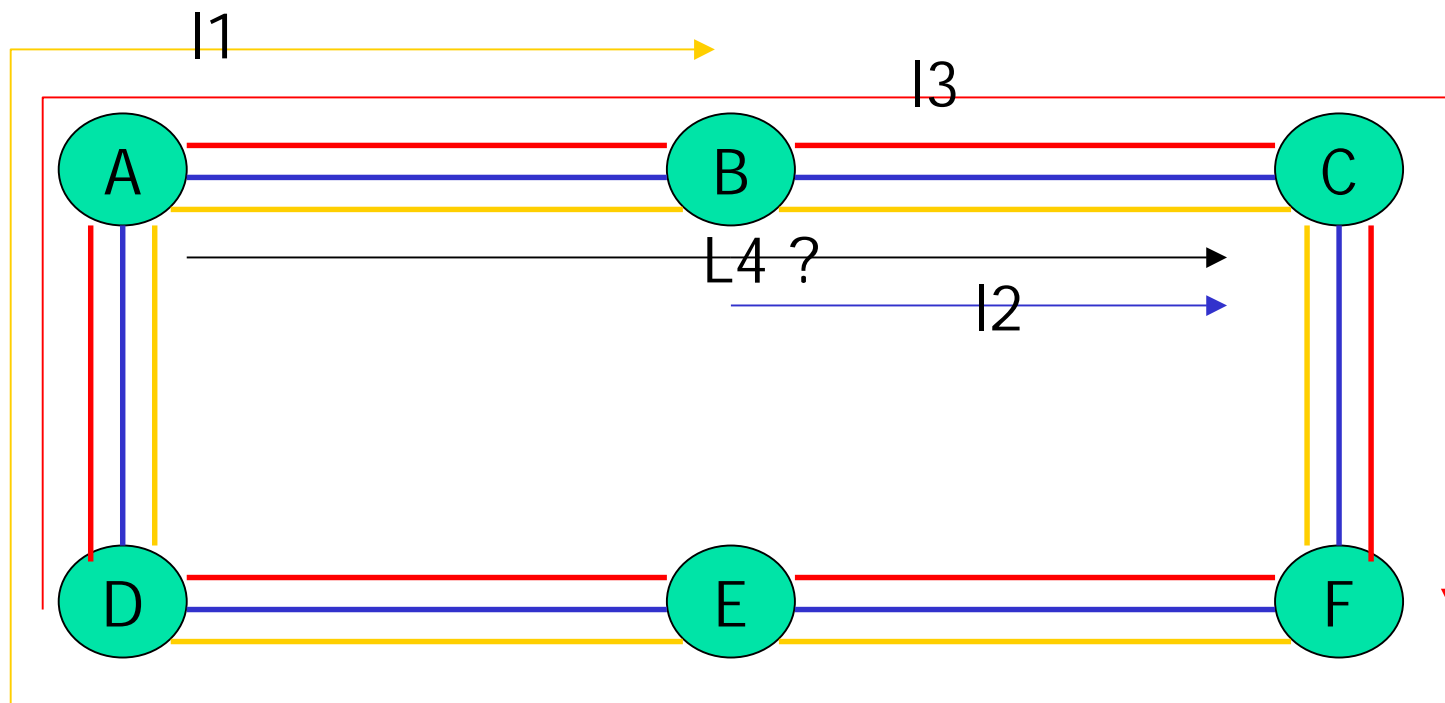

A WDM Wavelength Routing Network

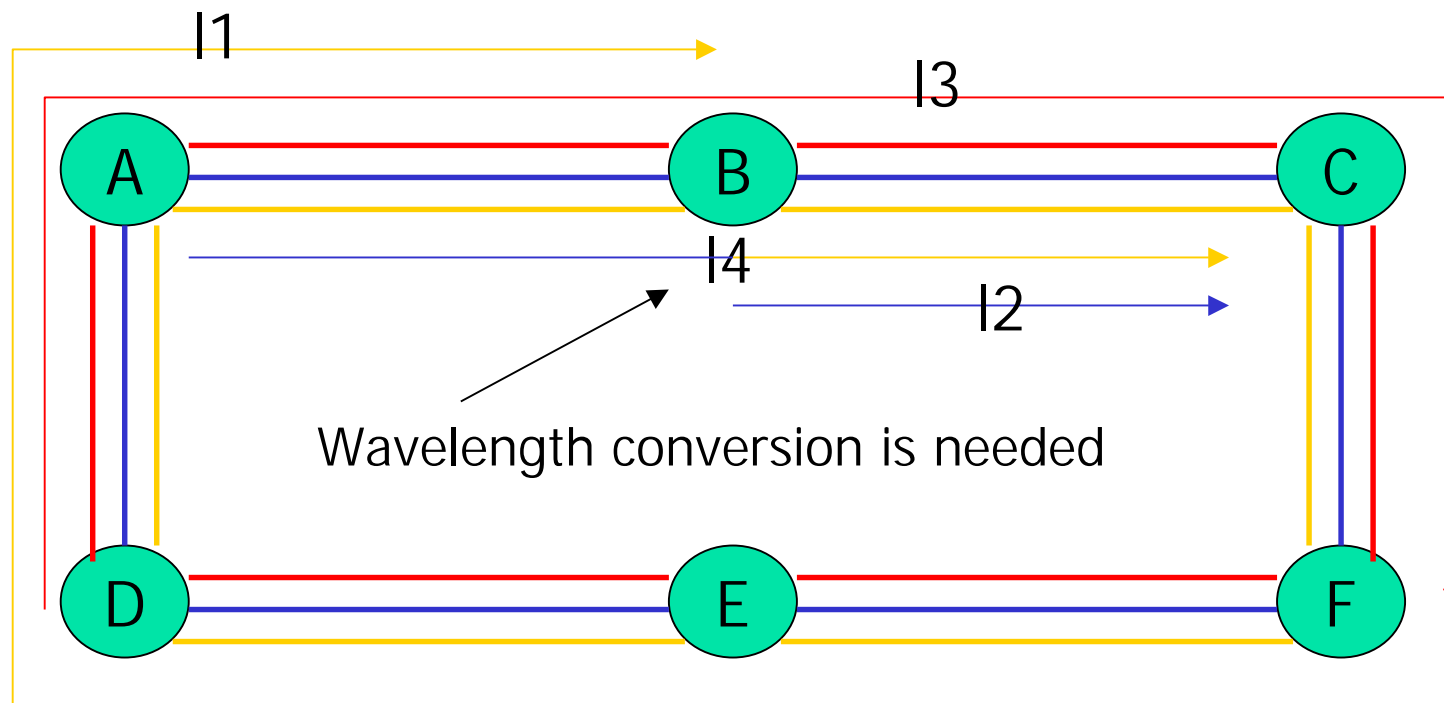



Wavelength Routing

- Spatial reuse of wavelengths: different lightpaths may use the same wavelength on different links.
- To enhance capabilities wavelength conversion may be considered.

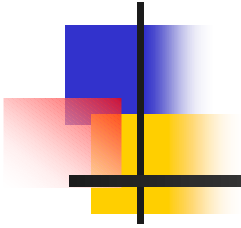

Key Optical Networking Elements



Key Networking Elements

- Optical Line Terminals (OLTs)
- Optical Add/Drop Multiplexers (OADM)s)
- Optical Crossconnects (OXC)s)



Optical Line Terminals (OLTs)

- Multiplexes multiple wavelengths of multiple fibres into a single fibre and demultiplexes a set of wavelengths of a single fibre into separate fibres.
- Located at the ends of WDM point-to-point links



Optical Add/Drop Multiplexers (OADMs)

- Takes signals at multiple wavelengths and **selectively** drops some wavelengths while letting others pass through. It can also selectively add a new wavelength (or substitute a wavelength) to the fibre without disturbing other wavelengths.
- Two line ports (in and out) and several local ports for wavelengths to be added/dropped.
- It may include wavelength conversion capabilities.



Optical Crossconnects (OXC)

- Essentially similar to an OADM, but larger scale.
- OXCs can have tens or even thousands of line ports and are able to switch wavelengths from one port to another.
- They may include conversion capabilities.
- There are many different types (to be elaborated later)

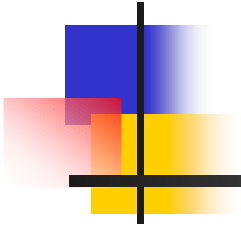

The Optical Layer



Protocol Stacks

- The ISO-OSI 7 layer model is a nice theoretical approach to network layering and functions.
- Unfortunately today in most networks functions are “smearing the boundaries” between layers.
- Furthermore in a more realistic model would have multiple protocol stack residing on each other.

Multiple Protocol Stacks

- E.g., IP over SONET

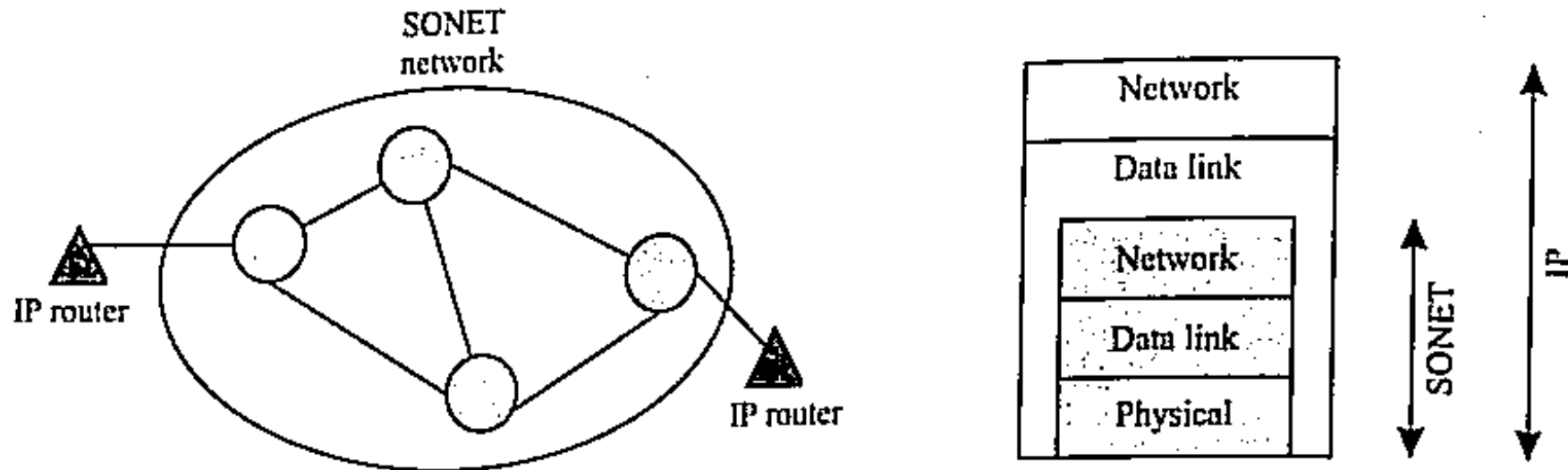

- SONET is used by IP to provide it with point-to-point links



Multiple Protocol Stacks

- Another (and even more complex) example is:
 - IP over ATM over SONET
- “Yet” another layer is added in second generation optical networks: the *optical layer*.

The Optical Layer

- Is a server layer providing services to client layers:
 - Provides lightpaths to a variety of higher layers
 - In future it may provide packet-switched virtual circuit or datagram services (3rd gen?)

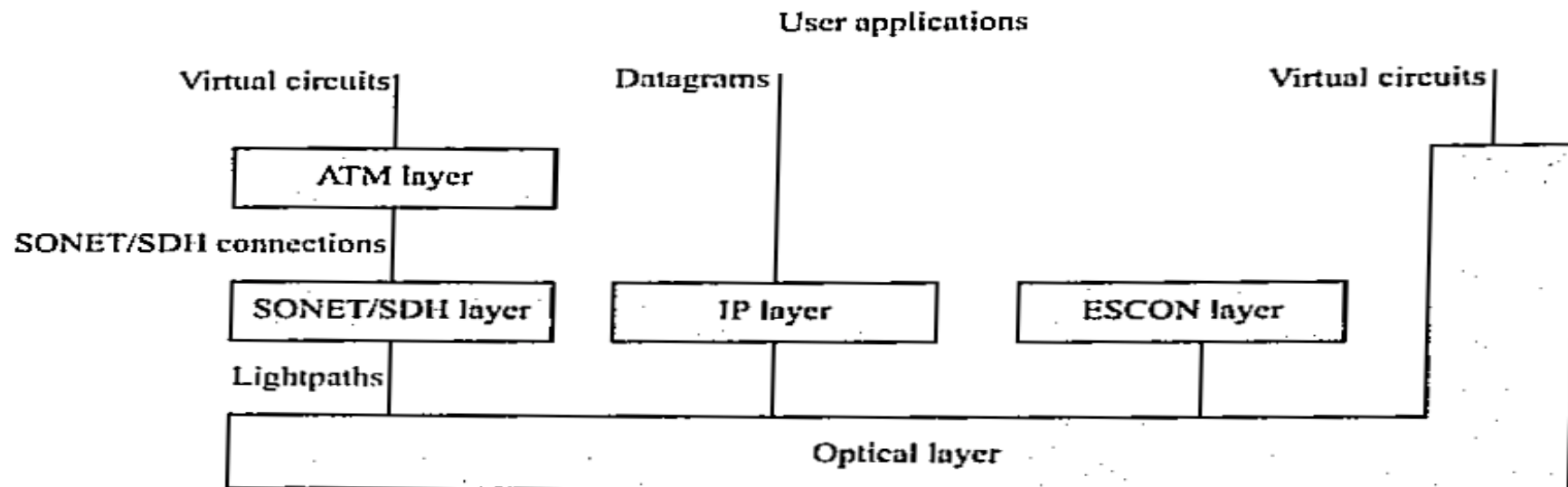



Lightpaths in the Optical Layer

- Lightpaths could be set-up or torn down by a request from a higher layer (similar to a circuit switched service like in PSTN).
- Lightpaths may be permanent (and thus fixed at the deployment of the network)



SONET vs. Optical Layer

- SONET used to be dominant transmission technology.
- The functions of the optical layer are analogous to those performed by the SONET layer. But it can handle other transmission technologies (more suited for data) as well. Furthermore the most effective processing speed for SONET is at 2.5Gbps, while light waves can easily carry 10Gbps.

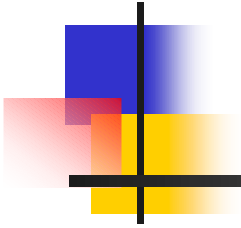

Transparency and All-Optical Networks



Transparency

- The optical layer can be transparent to the actual data sent over it, meaning that several higher layers can use the optical layer with their own physical specification.
- E.g., a certain maximum and minimum bit rate may be specified and any transmission between that will be routed by the lightpaths.



Advantages of Transparency

- Several different services can be provided on the same infrastructure.
- The infrastructure is somewhat future-proof.
- New services can be easily deployed
- (An example for an old and very popular transparent service is the one provided by the 4kHz band-limited telephone network (PSTN))



All-Optical Network

- Data is carried in optical form from source to destination.
- There is no electric-optical or optical-electric conversion but at the very source and destination nodes.
- Ideally an all-optical network is fully transparent, but in reality it is limited by, e.g., the SNR. (Optical reshaping techniques have not been invented yet.)



All-Optical Network

- Most networks today are not transparent, they can only provide for a single bit rate (2.5Gbps or 10Gbps) on wavelengths.
- Optical-electrical conversions may not be avoided. Electronic regeneration is needed depending on the length of the lightpath



Electronic Reshaping Techniques

- There are 3 types of electronic reshaping techniques:
 1. Regeneration with retiming and reshaping (3R)
 2. Regeneration with reshaping (2R)
 3. Simple retransmission, or simple OEO conversion (1R)



Regeneration With Retiming and Reshaping (3R)

- Bit clock is extracted from the signal.
- The signal is re-clocked.
- Results in a fresh copy of the signal.
- However it may eliminate transparency to bit rates and framing protocols.
- Large number of regenerations is possible



Regeneration With Reshaping (2R)

- No retiming compared to 3R.
- Provides transparency to bit rates
- Does not provide transparency to analogue (or multilevel) signals.
- Jitter accumulates at every regeneration step, thus there is a limit on the number of regenerators.



Simple Retransmission (1R)

- Signal is simply received and retransmitted.
- Can handle analogue data as well.
- Performance is *significantly* poorer than that of 2R or 3R.

- Optical amplifiers can be thought of as 1R regenerators



Transparency of Today's Networks

- Optical Networks are engineered and built to support several bit-rates and signal types (e.g., SONET, Gigabit Ethernet, etc.).
- Either 2R is employed or there are several 3R devices corresponding to supported bit rates and protocols.

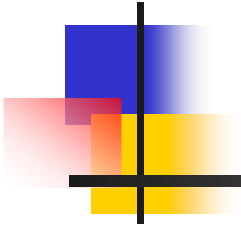

Optical Packet Switching



Optical Packet Switching

- Research topic.
- Packet switching in the optical domain.
- Both virtual circuits (portion of full bandwidth) and datagram services.
- Optical Time Domain Multiplexing (OTDM) can be fixed or statistical.
- If it is statistical then it is optical packet-switched network.



All-Optical Packet Switching

- Ideally , all functions would be performed in the optical domain
- Optical domain has limited capabilities
=>processing the header and controlling the switch remain in the electronic domain.
- The header could be sent by a lower speed (but ahead of time).
- Lack of optical RAM!! Optical buffers are simple delay lines not RAMs.
- Current packet switches include a high amount of electronics, that is difficult to perform in the optical domain.

Optical Packet Switching

- Fast optical switching is yet a problem.
- A node may impose a new header.

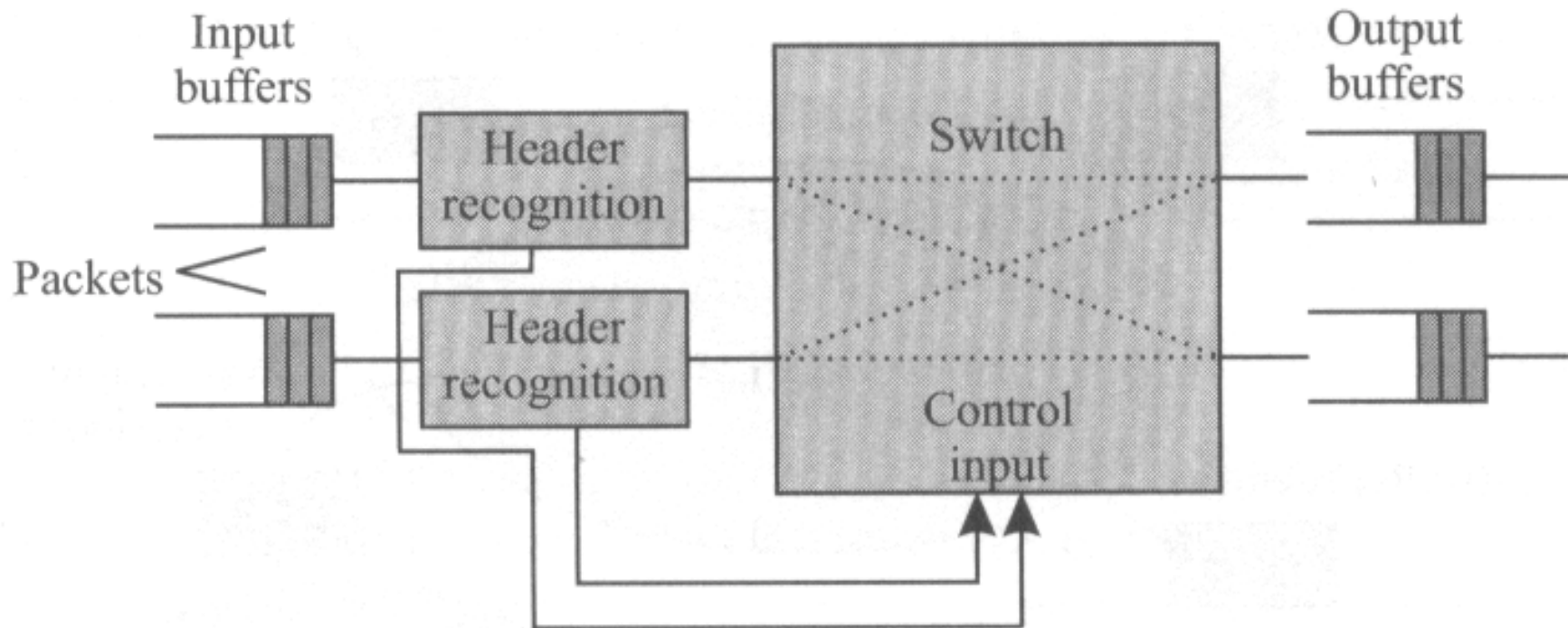

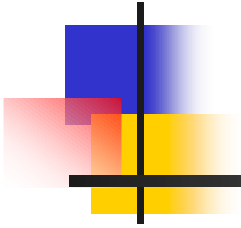

Transmission Basics



Wavelengths vs. Frequencies

- Wavelength of light pulse (λ): the length (in nm) of one sinusoid impulse in the transmission medium
- Frequency of pulse (f): How many sinus impulses are transmitted in a second (Hz, THz).
- Speed of light in the transmission medium(c): measured in m/s

$$c = \lambda f$$



Wavelengths vs. Frequencies

- Speed of light in vacuum: $3 \times 10^8 \text{m/s}$
- Approximate speed of light in fibre is $2/3$ of that of vacuum: $2 \times 10^8 \text{m/s}$ (thus the wavelengths corresponding to frequencies are also different).
- Typical wavelengths used are around: 800, 1300, and 1500nm (1500nm ~ 133THz)



Channel Spacing

- Around a center wavelength λ_0 .

$$\Delta f = -\frac{c}{\lambda_0^2} \Delta \lambda$$

- E.g., at a wavelength of $\lambda_0 = 1500\text{nm}$, 0.8nm spacing corresponds to 100GHz (typical in WDM).
- Channel spacing is needed to avoid interference between carriers



Spectral Efficiency

- Bandwidth is measured in: Hz, MHz, GHz
- Bit rate is measured in: bps, kbps, Mbps
- The relationship depend on the modulation used (e.g., PSTN: 4kHz bandwidth but we can use 56kbps).
- The ratio of bit rate to available bandwidth is called spectral efficiency.
- Optical spectral efficiency is typically around 0.4bps/Hz (i.e., for a 10Gbps bit rate 25GHz of bandwidth is needed)
- Channel spacing needs to be sufficiently larger!



Wavelength Standards

- 1550 nm band is the most frequently used band today:
 - Fibre loss is low
 - Good components are available
- Wavelengths (and frequencies) have been standardized by ITU (in the frequency domain – constant frequency spacing of 100 or 50GHz)

Typical Silica Fibre Characteristic

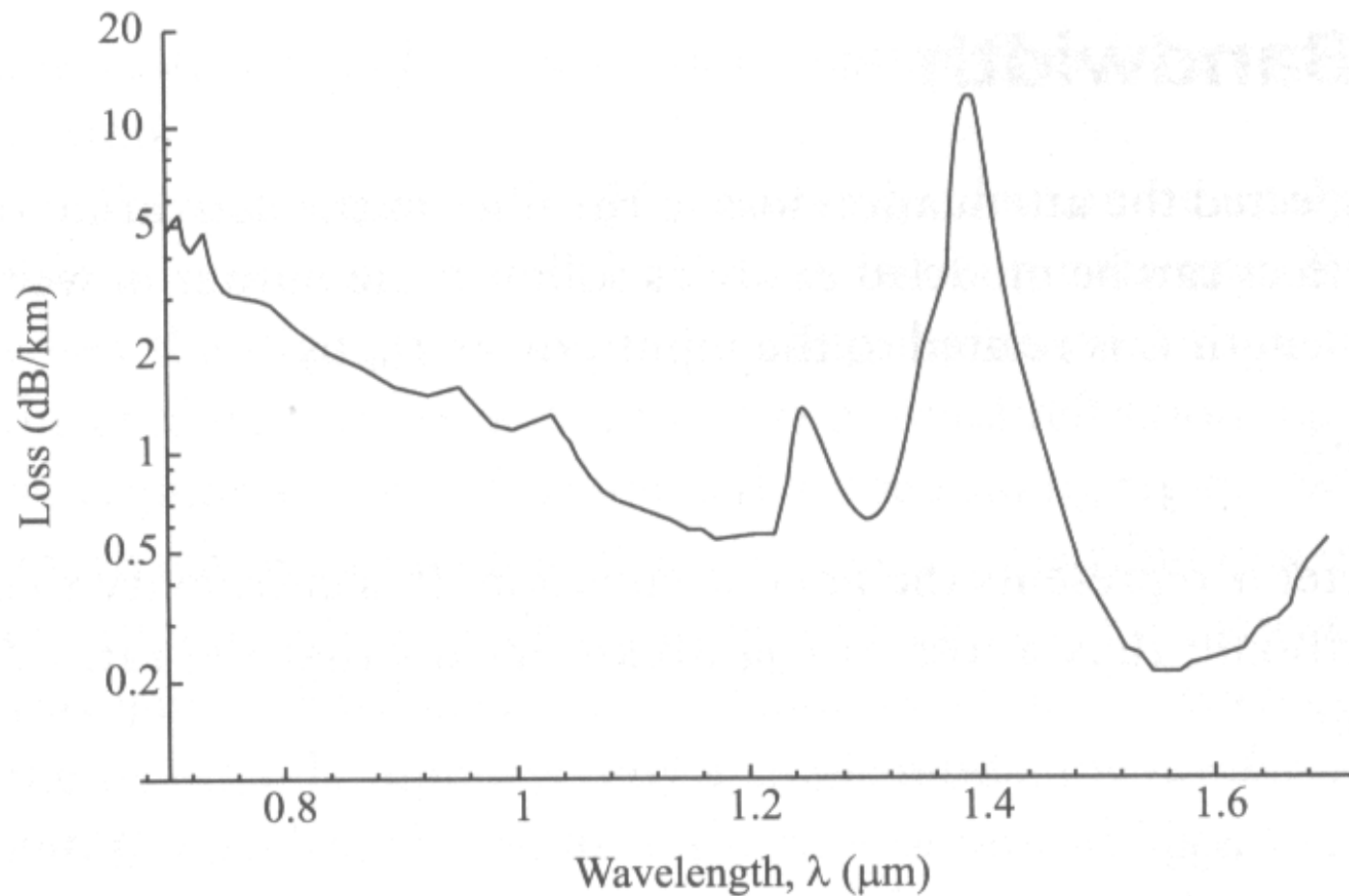

Wavelength Standards

- ITU 100GHz spacing standard

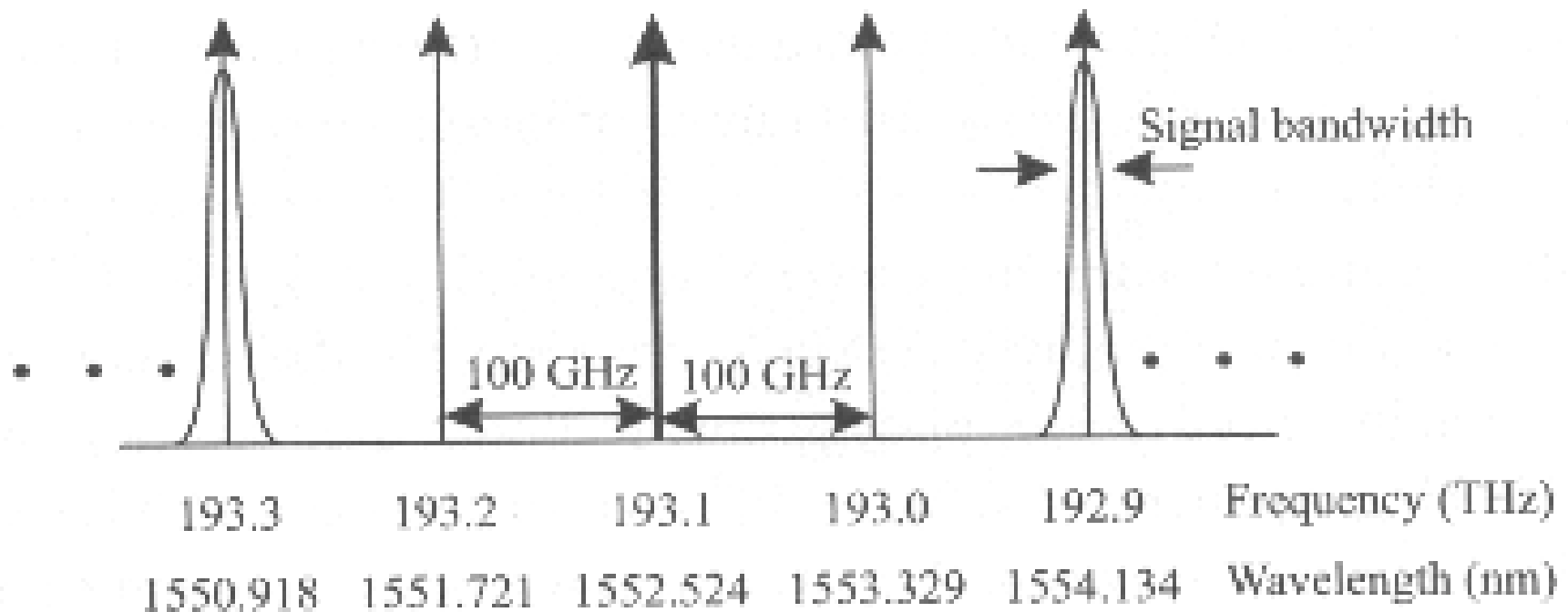



Wavelength Standards

- Today we see systems using 25GHz spacing, is ITU going to standardize that?
- Also C-band (1530-1565nm -conventional) equipment are available but L-band (1565-1625nm – long) is coming!
- Vendors don't always agree but this standardization effort helped accelerating the technology.

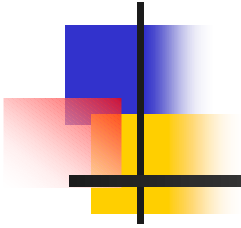

Optical Fibre Communication – Historical Overview



Waveguides

- Light signals can be transmitted in “waveguides” (~1960). (Waveguides enable light signals to be transferred without being scattered.)
- Waveguide consists of:
 - Core
 - Cladding
- Using total reflection

Early Days: Multimode Fibre

- Low loss optical fibre (1970).
- Core diameter ~ 50-80 μm . Step-index vs. Graded-index
- Length of different paths can differ significantly
=> intermodal dispersion
- Typical speeds: 32 – 140Mbps with regenerators every 10km

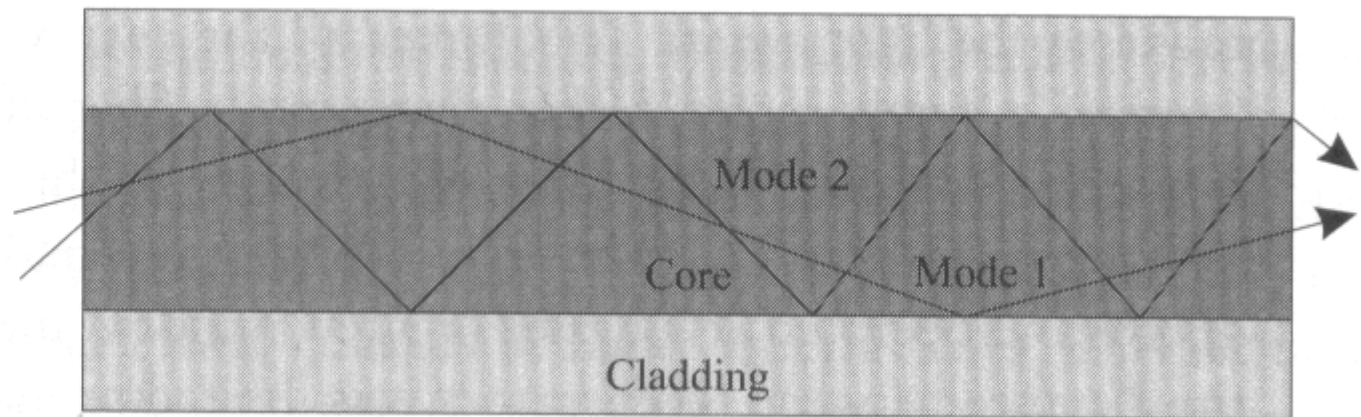
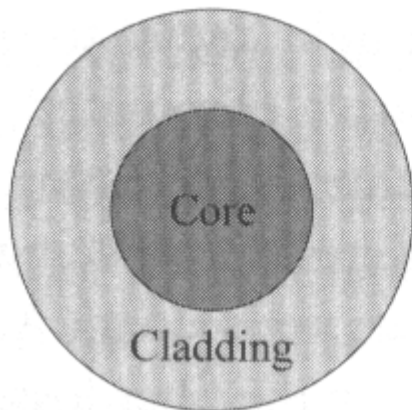



Early Days: LEDs

- Through the early 80s.
- 0.8 and 1.3 μm wavelengths.
- But light emission power was low while spectrum was too wide ($\times 10\text{nm}$).
- MLM (multilongitudinal mode) Fabry-Perot lasers have higher power but still transmit over a broad spectrum (hence the name) (note, spectrum is not continuous like with LEDs but ensembles periodic lines).
- Frequent regenerations were needed (every few km-s).



Single-Mode Fibre

- Starting 1984 single-mode fibre was commercially available (driven yet by MLM lasers at 1300nm).
- Relatively small core diameter (8-10 μ m) closer to the wavelength, forcing signals to travel in a single mode.
- => No intermodal dispersion, dramatic increase in bit rates (>100Mbps) and distances (>40km).



Longer Wavelengths

- 1550 nm lasers are available.
- Fibre loss is significantly less in this band => longer distances w/o regeneration.
- Chromatic dispersion becomes a problem (different wavelengths travel with a different speed). (Ironically chromatic dispersion is not present at 1300nm but is significant at 1550nm.)



Dispersion Shifted Fibre

- Goal: to reduce (make it zero) chromatic dispersion in the 1550nm band.
- But at that time already too many simple single-mode fibres were deployed. Another technique was needed to reduce chromatic dispersion in the 1550nm band.



Narrowing the Spectrum of Lasers (SLM Lasers)

- The bandwidth of the transmitted pulse is at least equal to its modulation bandwidth.
- But MLM Fabry-Perot laser's spectrum was way far more (hundreds of GHz) than the modulation bandwidth.
- Distributed Feedback (DFB) laser was developed (a DFB laser is a single-longitudinal laser (SLM)).
- Using DFB the bit rate in the 1550nm band can reach several Gbps.



Optical Amplifiers

- Development of Erbium-Doped Fibre Amplifiers (EDFA) in the late 1980s, early 1990s. (Theory was invented in the 1960s)
- Erbium atoms (a rare earth element) are doped into the fibre. Then they are “pumped” with a pump source to an “excited state” (high energy level).
- Erbium atoms are triggered back to normal state by incoming photons while emitting photons themselves.
- Pumping is done by a low-wavelength pump laser source (lower wavelength => higher energy ; this is needed to transfer energy to lower energy photons).
- Coincidentally Erbium works great in the 1550nm band.



EDFA

- Enables new generations of systems.
- They are capable to amplify signals at many different wavelengths simultaneously, thus EDFAs enable efficient use of WDM technology.
- Number of regenerators is significantly reduced => cost of long haul transmissions is greatly reduced (orders of magnitude).
- With WDM new connections can be brought up quickly (no need to deploy fibre ahead).



EDFA vs. Chromatic Dispersion

- With the use of EDFAs, chromatic dispersion became an important issue again.
- Solution: External modulator devices for lasers (instead of turning the lasers on and off). Speeds of 2.5Gbps per channel and distances over 600km are possible.



By Solving a Problem New Problems Arise

- Chromatic dispersion compensation techniques enable 10Gbps communication over the same distances.
- Second and third-order problems become significant:
 - Non-linear effects of fibres (e.g., four wave mixing (FWM, where 3 signals spawn a 4th)
 - Non-flat gain spectrum of EDFAs
 - Polarization related effects



Today

- New varieties of single mode fibres (less chromatic dispersion with less non-linear effects (almost a contradiction)).
- Hundreds of channel with 10Gbps and 50GHz spacing over a few thousand km-s between regenerators.
- Total capacities of >10 Tbs (research labs) with 40Gbps channels. (Today EDFAs work in the C and L band.)



Future?

- Development of amplifiers that work over different bands (e.g., Raman amplification) (S and U band)
- Development of new fibres that have good loss in other bands too (E band ; no amps yet).

Total bandwidth: $2 \times 10^8 / ((1675 - 1260) \times 10^{-9}) \sim 48 \text{THz}$

Band	Descriptor	λ range (nm)
O	Original	1260-1360
E	Extended	1360-1460
S	Short	1460-1530
C	Conventional	1530-1565
L	Long	1565-1625
U	Ultra-long	1625-1675



Using the Fibre

- First generation optical networks emerged in the 1980s.
- Metro networks and optical interfaces are deployed:
 - FDDI (Fibre Distributed Data Interface) (100Mbps)
 - ESCON (Enterprise Serial Connection) (200Mbps)
 - Today: Fibre Channel for storage networking (Gbps).
- Mass deployment of SONET/SDH



Using the Fibre

- Second generation networks evolved (Optical Layer).
- Wavelength Routing Networks.
- Lightpath on demand.
- Fibre to the Home (FTTH), Fibre to the Curb (FTTC) become reality. Fibre is getting closer to "us".
- Fibre is used as the backbone for many large companies, universities.